

TQ KRT2 DS - BLE Bluetooth Adapter

easyVFR EXPERIMENTAL

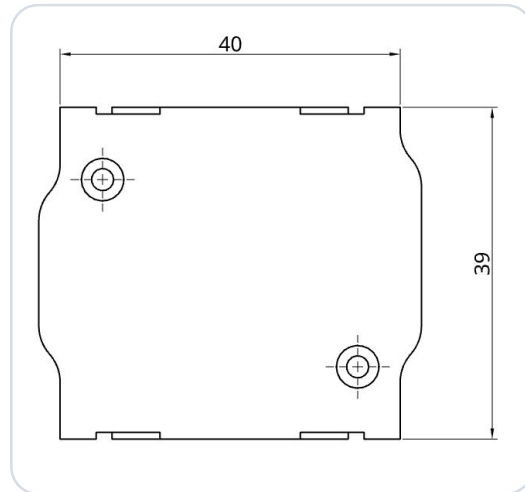

Bluetooth Low Energy Adapter (BLE) for a TQ KRT2 VHF transceiver (aviation radio). The adapter is compatible with radios of the following type series:

- KRT2-S
- KRT2-F
- KRT2-P

The adapter was developed as an interface for the TQ KRT2 for compatible navigation apps (e.g., easyVFR) and works together with an EFIS. It enables data transfer between the navigation app and the radio hardware (BLE ↔ RS-232). The adapter is simply plugged between the existing wiring and the radio and is held securely to the housing thanks to the Conec latch system.

An additional power supply is not required. The adapter can be operated with 12 V and 24 V onboard voltage. An internal mini-fuse (125 mA) is integrated in the housing.

The power supply is protected against reverse polarity and short-circuit-proof. **No further electrical or mechanical work necessary!**

IMPORTANT

This is a prototype for exclusively experimental use!

1 Radio Configuration

No further configuration of the radio is required.

2 Connector Pin Assignment

This is an excerpt from the TQ installation manual:

IMPORTANT

Pin 13 of the connector serves as data input from the EFIS.

6.9.2 Connector Pin-Configuration

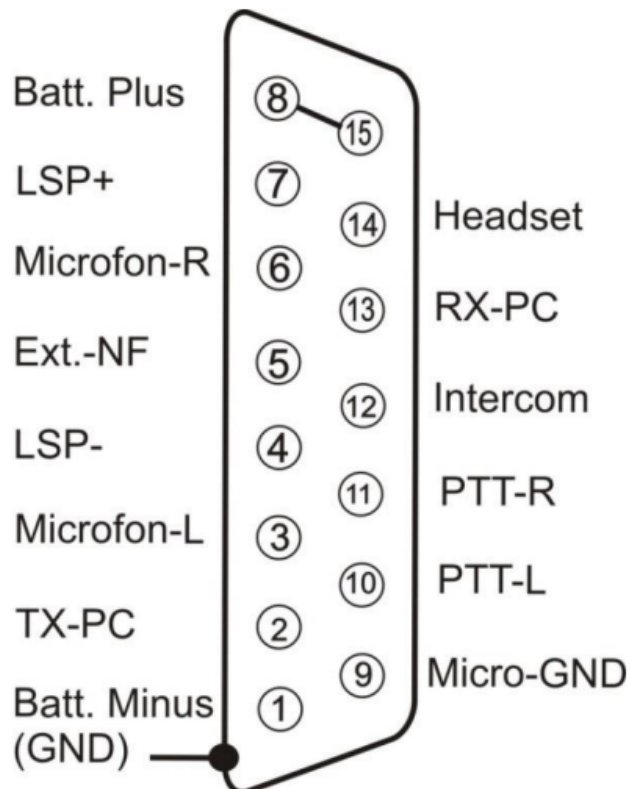

Figure 7: Connector pinout

Figure 1 · KRT2 DS Connector Pin Assignment

3 Configuration in EasyVFR

IMPORTANT

Do not pair the SD-Link in the Bluetooth settings

The SD-Link adapter is a Bluetooth Low Energy (BLE) device. BLE devices are not paired via the Bluetooth settings of your tablet or phone like regular Bluetooth devices such as headsets or speakers.

Therefore, please do not open the Bluetooth settings of iOS, Android or Windows to search for or pair the SD-Link there.

The connection to the SD-Link is set up exclusively within the navigation app itself, e.g. in SkyDemon, Sky-Map, VFRnav, EasyVFR or another supported app. Pairing at operating-system level is not required and can even prevent the connection.

Regular Bluetooth devices such as headsets, intercoms or speakers can still be used in parallel. They are paired via the operating system as usual. The SD-Link, however, is addressed directly by the navigation app.

If the SD-Link has already been paired in the Bluetooth settings: Please remove the SD-Link completely from the Bluetooth device list of your tablet or phone. Do not pair it again via the operating system afterwards; instead, set it up again exclusively within the navigation app.

REMEMBER

**Do not pair the SD-Link in the operating system.
Always set up the SD-Link directly in the navigation app.**

3.1 Enable Bluetooth and select radio

- Switch on aircraft power, turn on the radio.
- Enable Bluetooth on your phone / tablet.
- Start EasyVFR4.

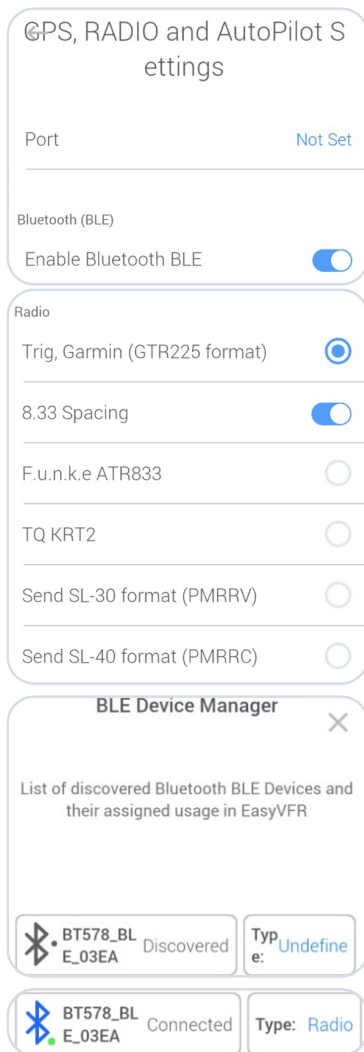

3.1.1 Enable Bluetooth BLE in EasyVFR

- ① Open menu
- ② **System** → **GPS, Radio and AutoPilot Settings**
- ③ Scroll down and activate option **Enable Bluetooth BLE**

3.1.2 Select radio protocol

- ① Continue scrolling down to the Radio section
- ② Select matching radio/protocol
- ③ If your device is not listed: test protocols, recommended from top to bottom
 - **GTR225** is the most comprehensive (incl. 8.33 kHz),
 - **SL40/SL30** are older legacy protocols.

3.1.3 Open BLE device list and assign adapter

- ① EasyVFR now continuously scans for BLE devices
- ② Menu → **Bluetooth BLE devices**
- ③ Select the adapter from the list (e.g. **SD-KRT2**)
- ④ Tap the Type until **Radio** is set (cycle: AutoPilot / GPS/Traffic / Radio / undefined)
- ⑤ EasyVFR connects; indicated by "Connected" (incl. Bluetooth icon).

3.1.4 Send frequencies (Remote Tuning)

① Tap frequency in:

Airfield Info	
TWR	135.180 Lelystad Tower 123.830
ATIS	120.730 Lelystad Information H24
CLD	123.680 Lelystad Delivery 123.830 Start-up and clearance delivery
APP	134.530 Lelystad Arrival 120.830

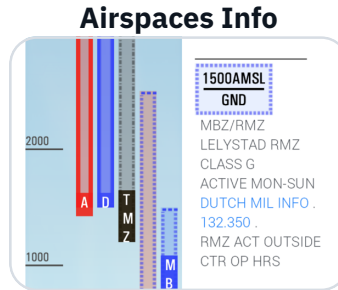

Radio and Position	
N52 27 31.0 E005 31 27.7 0.5NM NE of EHLE-Lelystad 3.6NM S of Lelystad (NL)	
Departure EHLE Lelystad, -12ft Density Altitude -396ft	
ATIS	120.730 Lelystad Information
CLD	123.680 Lelystad Delivery
TWR	135.180 Lelystad Tower
APP	134.530 Lelystad Arrival

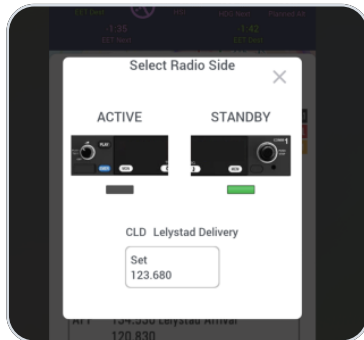

② Then select **Active** or **Standby** (depending on the radio, only Standby may be possible) → press **Set**.

3.1.5 Optional control aids (Radio Card)

Radio and Position	
N52 27 31.0 E005 31 27.7 0.5NM NE of EHLE-Lelystad 3.6NM S of Lelystad (NL)	
List of previously selected frequencies	
RDO	121.005 Teuge Radio
	132.350 DUTCH MIL INFO
APP	119.055 Schiphol Approach
CLD	123.680 Lelystad Delivery
TWR	135.180 Lelystad Tower
ATIS	120.730 Lelystad Information
MISC	134.480 Gilze Monitor
APP	134.530 Lelystad Arrival

① Keypad icon: manual frequency entry

② Clock icon: recently set frequencies (History)

4 Contact

If you have any questions, problems or feedback, please feel free to contact us:

LayCom Vision GmbH – SD-Link

Michael Hoffmann

Chausseestr. 46
D-15518 Rauen, Germany

E-Mail info@sdlink.de

Phone **+49 3361 710253**

Web www.sdlink.de

