

TQ KRT2 – angled Adapter BLE Bluetooth

vfrNav EXPERIMENTAL

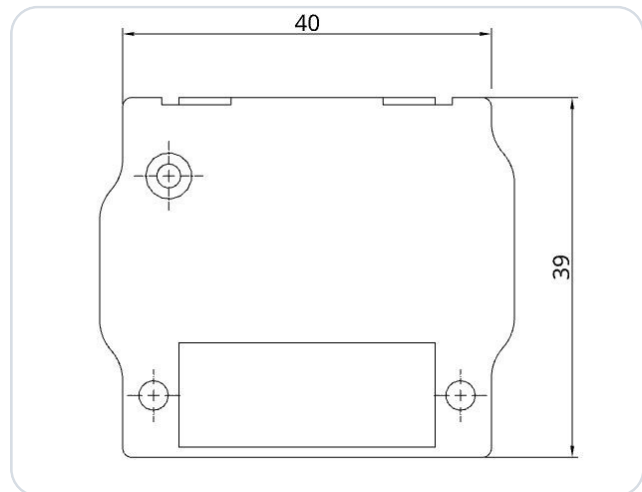

Angled version of the Bluetooth Low Energy adapter (BLE) for a TQ KRT2 VHF transceiver (aviation radio), designed for installations with limited space behind the radio unit. The adapter is compatible with the following radio models:

- KRT2-S
- KRT2-F
- KRT2-P

The adapter was developed as an interface between a TQ KRT2 and the navigation software vfrNav. It realizes the data transfer conversion between the navigation software (SD) and the radio hardware (BLE ↔ RS-232). The adapter is simply plugged between the existing cabling and the radio and holds securely to the housing thanks to the Conec latch system.

No additional power supply is required. The adapter can be operated with 12 V and 24 V onboard voltage. An internal mini-fuse (125 mA) is integrated in the housing.

The power supply is protected against reverse polarity and short-circuit proof. **No further electrical or mechanical work required!**

IMPORTANT

This is a prototype for experimental use only!

1 Radio Configuration

No additional configuration is required on the radio unit.

2 Connector Pin Assignment

This is an excerpt from the TQ installation manual:

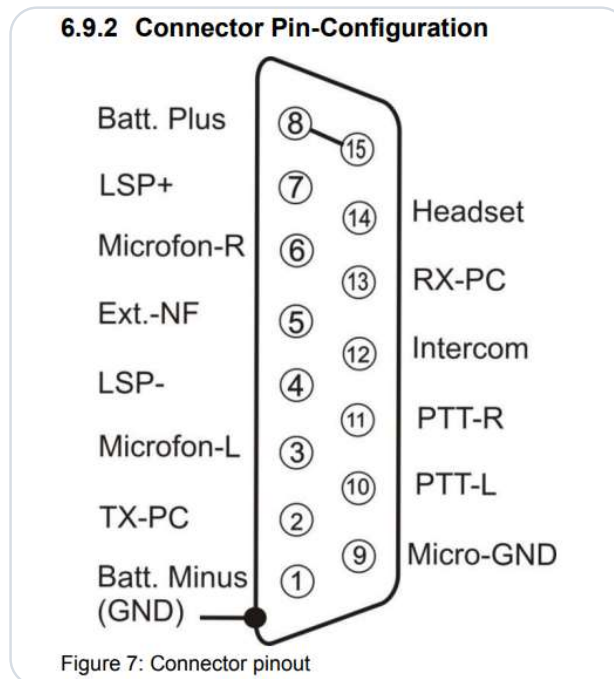

Figure 1 · KRT2 Connector Pinout

3 Product Variants

The mechanical orientation of the connector differs between the KRT2-S and KRT2-F. This changes the direction in which the adapter is angled. Therefore, please pay attention to the respective radio unit when selecting the product variant (LEFT/RIGHT).



For this reason, there are the product variants **SD-KRT2-A-LEFT** and **SD-KRT2-A-RIGHT**.

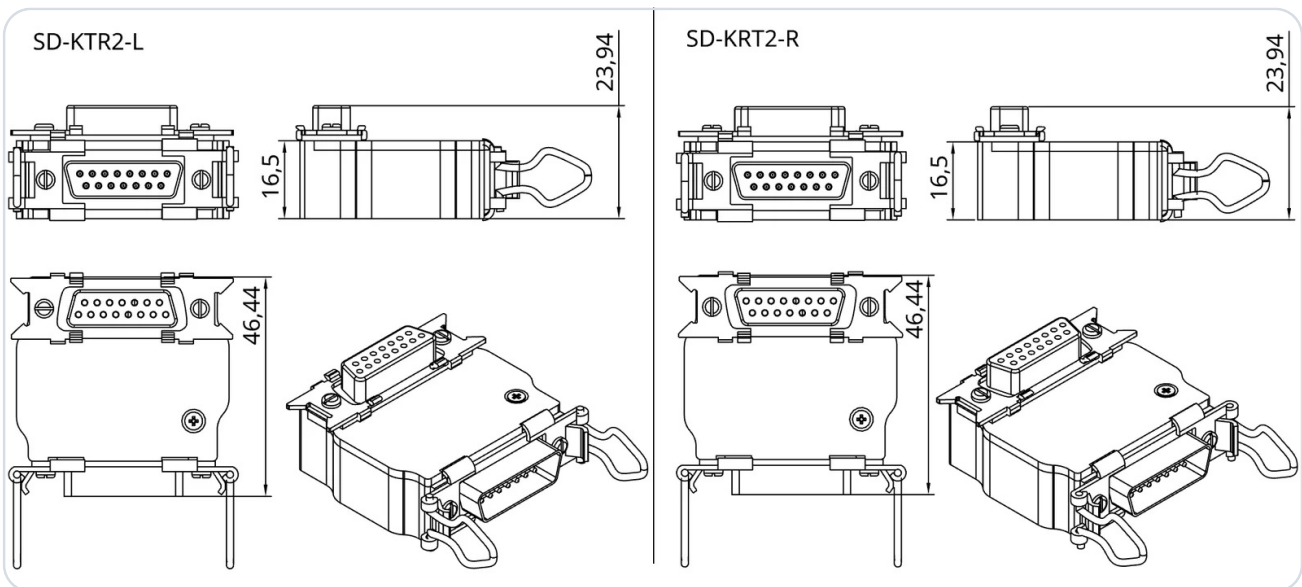

3.1 Orientation of LEFT/RIGHT per Radio Unit

Device	Desired Orientation	Required Adapter
KRT2-F	Points upward	SD-KRT2-A-LEFT
KRT2-F	Points downward	SD-KRT2-A-RIGHT
KRT2-S	Points downward	SD-KRT2-A-LEFT
KRT2-S	Points upward	SD-KRT2-A-RIGHT

4 Configuration in vfrNav

IMPORTANT

Do not pair the SD-Link in the Bluetooth settings

The SD-Link adapter is a Bluetooth Low Energy (BLE) device. BLE devices are not paired via the Bluetooth settings of your tablet or phone like regular Bluetooth devices such as headsets or speakers.

Therefore, please do not open the Bluetooth settings of iOS, Android or Windows to search for or pair the SD-Link there.

The connection to the SD-Link is set up exclusively within the navigation app itself, e.g. in SkyDemon, Sky-Map, VFRnav, EasyVFR or another supported app. Pairing at operating-system level is not required and can even prevent the connection.

Regular Bluetooth devices such as headsets, intercoms or speakers can still be used in parallel. They are paired via the operating system as usual. The SD-Link, however, is addressed directly by the navigation app.

If the SD-Link has already been paired in the Bluetooth settings: Please remove the SD-Link completely from the Bluetooth device list of your tablet or phone. Do not pair it again via the operating system afterwards; instead, set it up again exclusively within the navigation app.

REMEMBER

Do not pair the SD-Link in the operating system.

Always set up the SD-Link directly in the navigation app.



- Switch on aircraft power, turn on the radio.
- Enable Bluetooth on your phone/tablet.
- Start vfrNav.
 - ① Open menu
 - ② Open settings menu
 - ③ Under Device connections → Radio
 - ④ Select interface

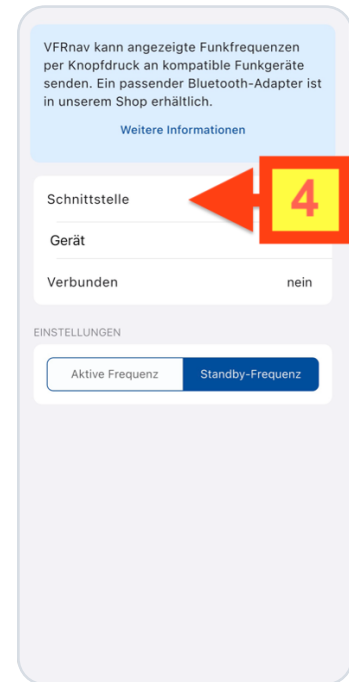
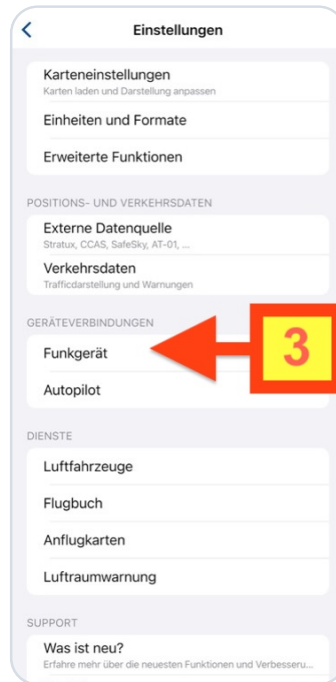
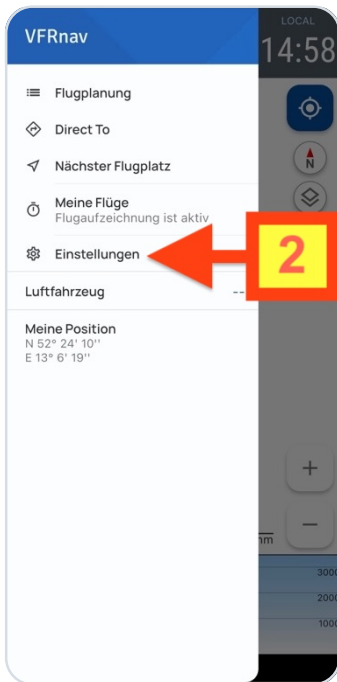

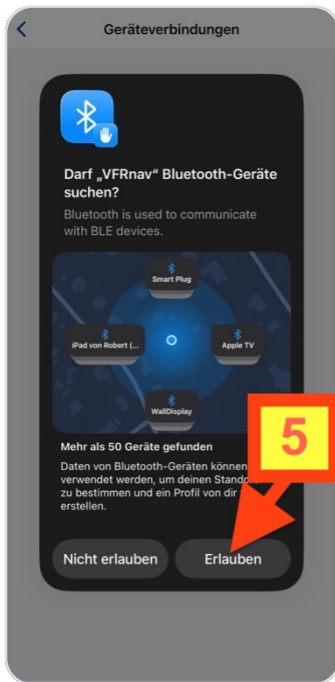

- ⑤ Enable Bluetooth if necessary
- ⑥ Select the name of the found adapter: **SD-KRT2**
- ⑦ If the protocol was not automatically detected, please adjust it under „Gerät" anpassen.
- ⑧ In the connection settings, specify whether the frequency should be transmitted to the radio immediately as active or as standby.

IMPORTANT NOTICE

Check under „Verbunden": It should say „ja" stehen.

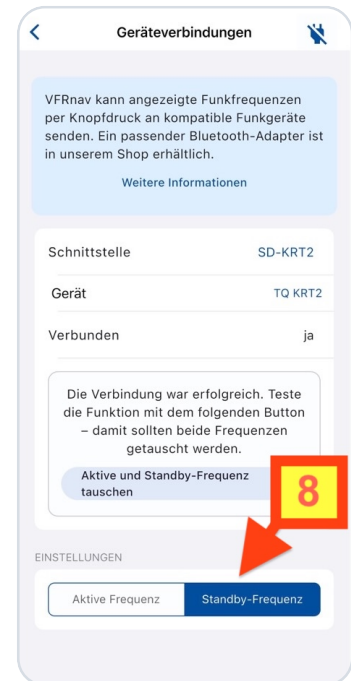
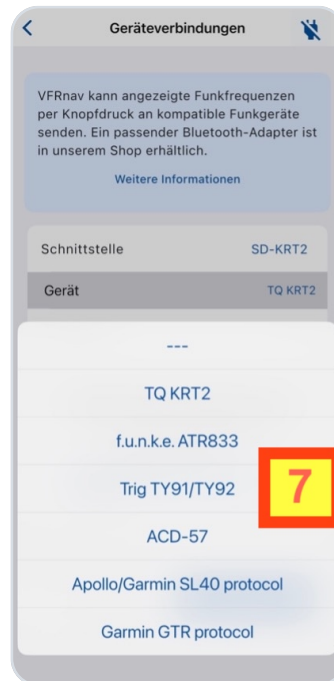
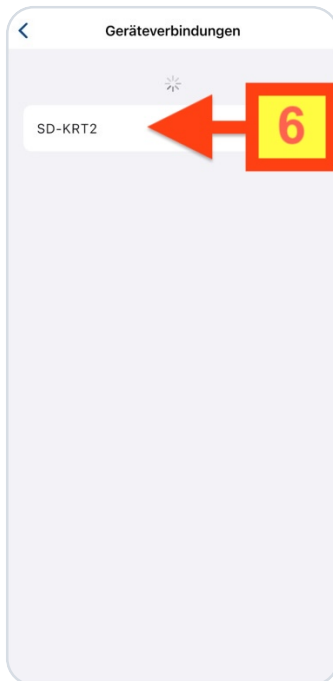

5 Contact

For problems, questions, suggestions or even positive feedback, please contact:

LayCom Vision GmbH – SD-Link

Michael Hoffmann

Chausseestr. 46
D-15518 Rauen, Germany

E-Mail info@sdlink.de

Phone [+49 3361 710253](tel:+493361710253)

Web www.sdlink.de

