

Generic Adapter BLE Bluetooth DS (Dual Source)

easyVFR EXPERIMENTAL

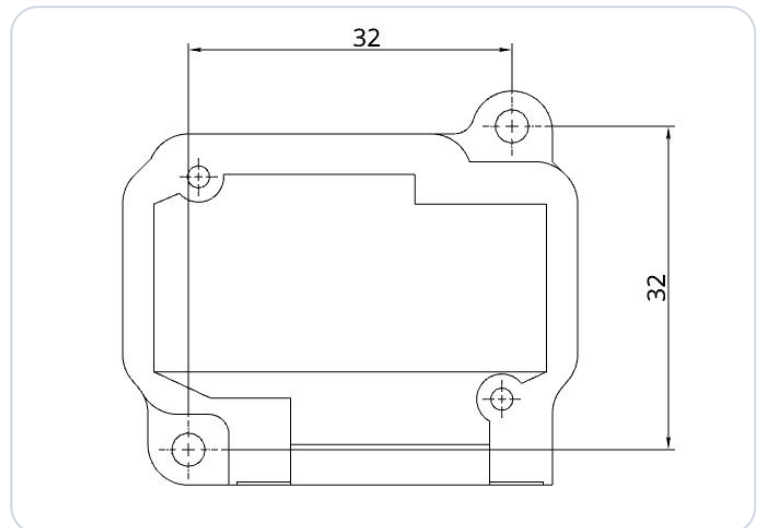

Bluetooth Low Energy Adapter (BLE) developed for the navigation software easyVFR.

It implements the data transfer between the navigation software (SD) and the avionics hardware (BLE ↔ RS-232) and also works with an existing RS-232 data source, e.g. an EFIS (Dynon, Garmin G3X, etc.) for radio frequency setting.

Set the frequencies of your VHF transceiver, control your autopilot, feed your AV-30 with this Bluetooth adapter directly from the easyVFR App.

This adapter has only the basics you need to connect the easyVFR navigation software to your avionics. Mount it somewhere behind the panel, connect power and distribute the signals to the devices. Yes, this sounds like tinkering... but you want it that way ;-)

The adapter can be operated with 12 V and 24 V aircraft voltage. A self-resetting mini-fuse is integrated in the housing. The power supply is protected against reverse polarity and short circuit.

IMPORTANT

This is a prototype for experimental use only!

1 Radio Configuration

Must be performed according to the respective device. TRIG TY91/92/96, f.u.n.k.e ATR833, TQ KRT2, GARMIN GTR225 / GNC225 do not require any further settings on the radio.

2 Connector Pin Assignment

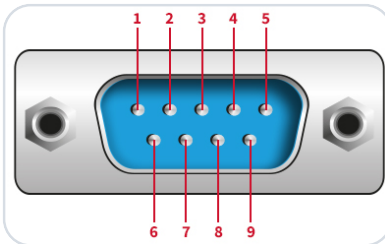

Pin	Function	Description
Pin 1	Data TXD	Output 2 - V24 data to EFIS
Pin 2	Data RXD	Input 1 - V24 data from Radio
Pin 3	Data TXD	Output 1 - V24 data to Radio
Pin 4	Data RXD	Input 2 - V24 data from EFIS
Pin 5	GND	
Pin 8	Power	+ 5 ... 28 V

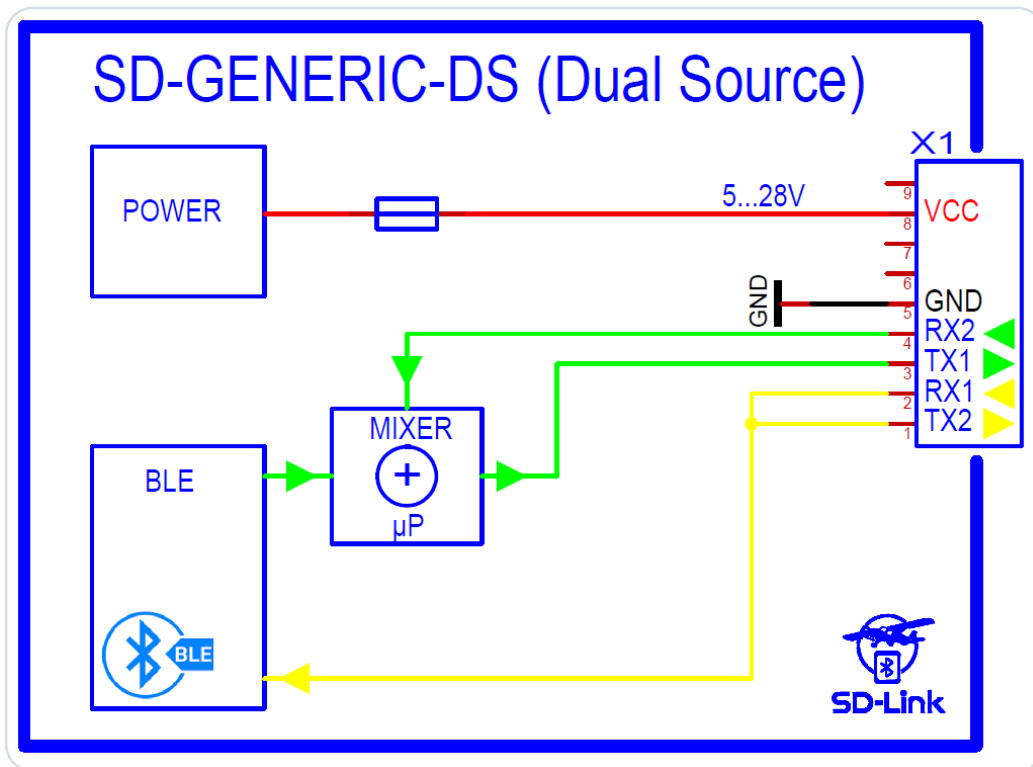

3 Wiring Diagram

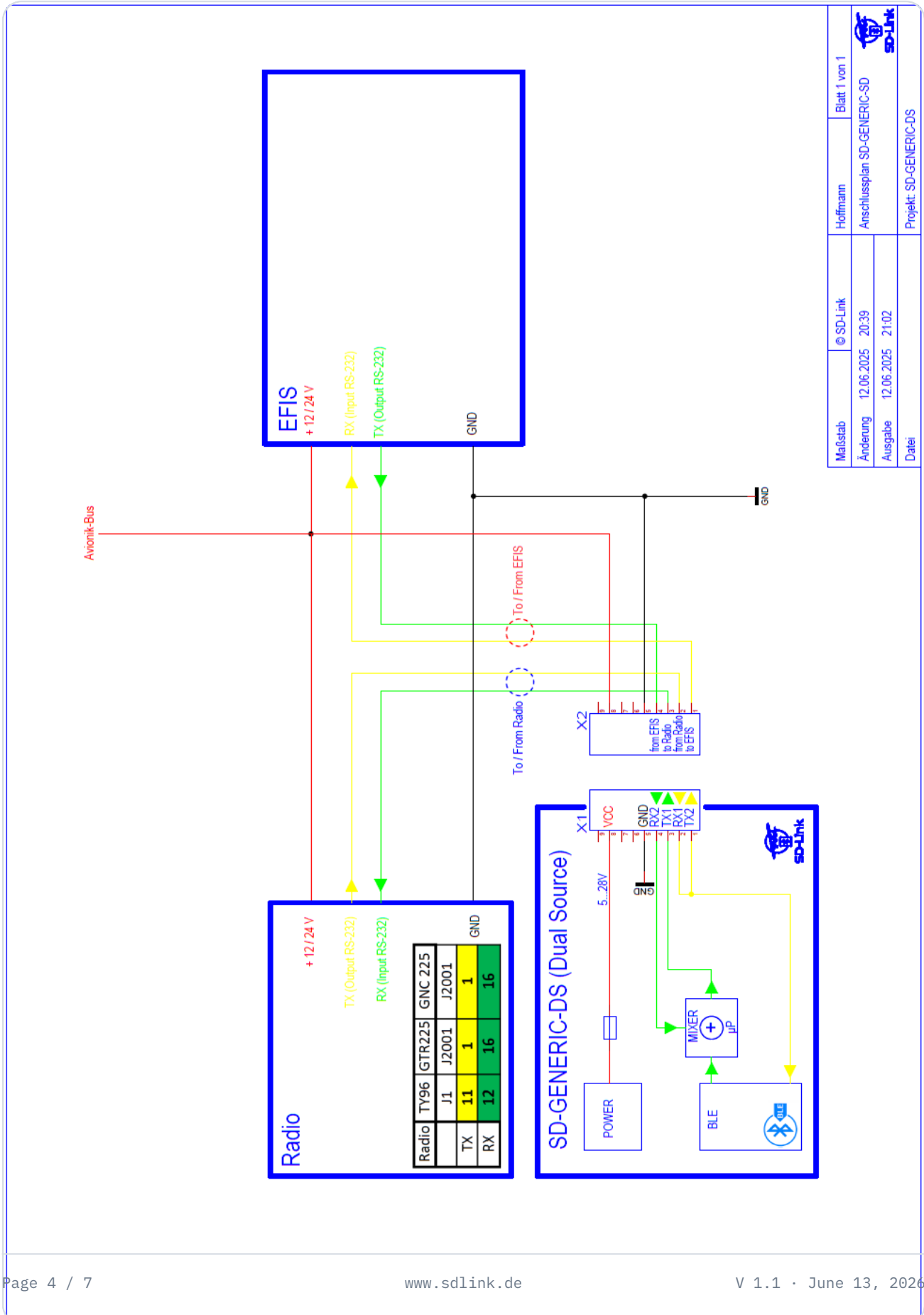

Figure 1 · Wiring Diagram SD-GENERIC-DS

4 Cable Harness

A pre-configured cable harness is available for connection (**SD-GENERIC-CAB-02**).

The connection is made using a Conec Snap-Lock adapter and prepared MIL M39029/63-368 crimp contacts. In the best case, these can simply be "snapped" into the existing Sub-D connector.



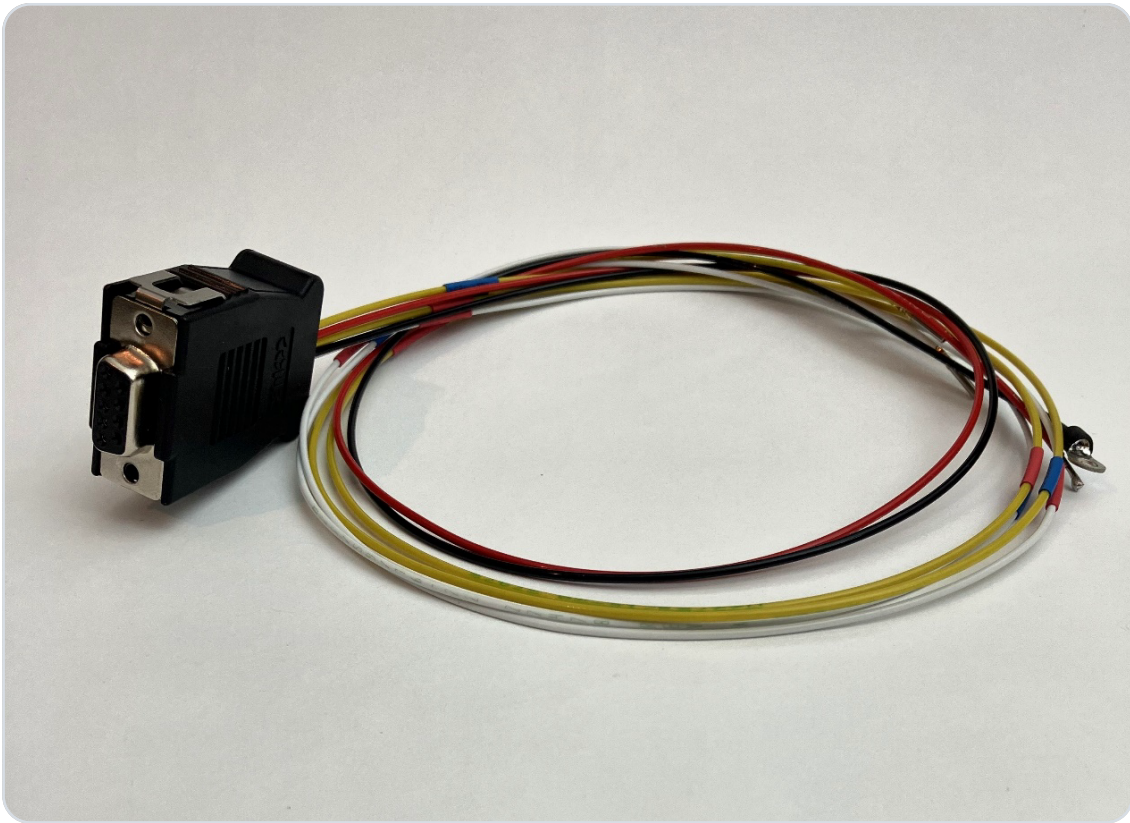

5 Contact

For problems, questions, suggestions or positive feedback, please contact:

LayCom Vision GmbH – SD-Link

Michael Hoffmann

Chausseestr. 46
D-15518 Rauen, Germany

E-Mail info@sdlink.de

Phone **+49 3361 710253**

Web www.sdlink.de



Dimensions

