

# f.u.n.k.e ATR833 Adapter BLE Bluetooth

## XCSoar (Android) EXPERIMENTAL

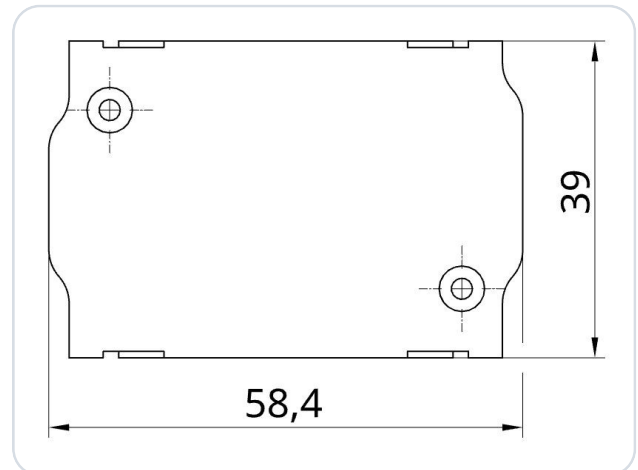

Bluetooth Low Energy adapter (BLE) for a f.u.n.k.e ATR833 VHF transceiver (aviation radio). The adapter was developed as an interface for a f.u.n.k.e ATR833 to the navigation software SkyDemon (SD). It implements the data transfer between the navigation software (SD) and the radio hardware (BLE ↔ RS-232). The adapter simply connects to the radio.

No additional power supply is required. The adapter is powered through the radio. A self-resetting fuse is integrated in the housing. The power supply is protected against reverse polarity and short-circuit proof.

**No further electrical work necessary!**

### IMPORTANT

This is a prototype for experimental use only!

# 1 Radio Configuration

**IMPORTANT**

Supported are ATR833-S, ATR833-A and ATR833-II-OLED from software SW 5.8. Older versions ( $\leq 5.7$ ) are not compatible. First supported serial number: 40131610 (2010). Tip: the last two digits of the serial number = year of production.

No further configuration is required on the radio.

# 2 Connector Pin Assignment

This is an excerpt from the f.u.n.k.e installation manual:

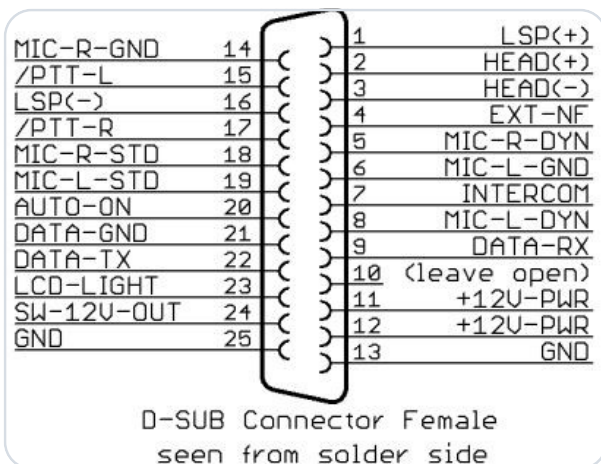

Figure 1 · Old Version (ATR833)

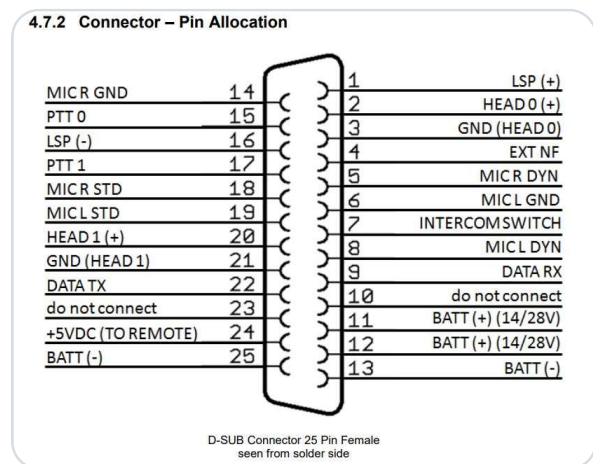

Figure 2 · New Version (ATR833-II)

## D-SUB 25-Pin · Pin Allocation in Detail

D-SUB 25-pin female connector, solder side. Complete allocation according to the f.u.n.k.e manual.

PIN	NAME	FUNCTION
1	LSP (+)	Output external Loudspeaker Positive
2	HEAD-0 (+)	Output Headset-Speaker Positive
3	GND (HEAD-0)	Output Headset-Speaker Negative
4	EXT-NF	Input external Audio-Signal
5	MIC R DYN	Input Microphone Right Dynamic
6	MIC L GND	Input Microphone Left Ground
7	INTERCOM SWITCH	Intercom Activation Switch (connect to ground for Intercom activation)
8	MIC L DYN	Input Microphone Left Dynamic
9	DATA-RX	RS232 Receive (for Remote Control)
10	do not connect	Pin 10 is used by adapters for device identification
11	+14 / +28V-PWR	Input Power Supply +12V
12	+14 / +28V-PWR	Input Power Supply +12V
13	BATT (-)	Ground Side of Power Supply
14	MIC R GND	Input Microphone Right Ground
15	PTT-0	Push-to-Talk 0 (connect to ground for transmitting)
16	LSP (-)	Output external Loudspeaker Negative (Not identical to ground!)
17	PTT-1	Push-to-Talk 1 (connect to ground for transmitting)
18	MIC R STD	Input Microphone Right (Headset 1)
19	MIC L STD	Input Microphone Left (Headset 0)
20	HEAD 1 (+)	Output 1 Headset-Speaker Positive
21	GND (HEAD 1)	Output 1 Headset-Speaker Negative
22	DATA-TX	RS232 TX (for Remote Control)
23	N/A	do not connect
24	+5VDC OUT	5VDC Power Supply for Remote Control
25	BATT (-)	Ground Side of Power Supply

Source: f.u.n.k.e manual.

## 3 Configuration in XCSoar

### IMPORTANT

#### Do not pair the SD-Link in the Bluetooth settings

The SD-Link adapter is a Bluetooth Low Energy (BLE) device. BLE devices are not paired via the Bluetooth settings of your tablet or phone like regular Bluetooth devices such as headsets or speakers.

Therefore, please do not open the Bluetooth settings of iOS, Android or Windows to search for or pair the SD-Link there.

The connection to the SD-Link is set up exclusively within the navigation app itself, e.g. in SkyDemon, Sky-Map, VFRnav, EasyVFR or another supported app. Pairing at operating-system level is not required and can even prevent the connection.

Regular Bluetooth devices such as headsets, intercoms or speakers can still be used in parallel. They are paired via the operating system as usual. The SD-Link, however, is addressed directly by the navigation app.

**If the SD-Link has already been paired in the Bluetooth settings:** Please remove the SD-Link completely from the Bluetooth device list of your tablet or phone. Do not pair it again via the operating system afterwards; instead, set it up again exclusively within the navigation app.

### REMEMBER

**Do not pair the SD-Link in the operating system.  
Always set up the SD-Link directly in the navigation app.**

### IMPORTANT

#### XCSoar: experimental and Android only

This guide describes the tested setup with XCSoar on **Android** (tested from XCSoar 7.42 onwards). XCSoar support is experimental and depends on the XCSoar version, the Android device and the radio driver.

On **iOS**, up to and including version 7.44, XCSoar offers – according to our testing – no BLE port for external devices; only internal sensors and TCP/UDP are available as port types, so the SD-ATR833-E cannot be used directly on iOS. For iOS, please use one of the other supported apps (e.g. SkyDemon).

### 3.1 Requirements

- Onboard power on, radio switched on.
- Switch on Bluetooth on your Android device.
- Start XCSoar.

### NOTE

No pairing is required. The SD-ATR833-E is a BLE device and is selected exclusively within XCSoar – not in the Bluetooth settings of Android (see the note above).

### 3.2 Adding the device in XCSoar

- ① Double-tap the map view to open the menu and select **Config** → **Devices**.
- ② Choose a free slot (e.g. **B**) and tap **Edit**.

- Open **Port**, select the entry **SD-ATR833** with the type **BLE port** and confirm with **Select**.

**IMPORTANT NOTICE**

Make sure to pick the type **BLE port**. Entries with a bare MAC address or the type **BLE sensor** are not correct; classic **Bluetooth** devices (e.g. headsets) are not correct either. No pairing is required.

- As **Driver**, select the radio type **ATR833**.
- Leave the edit dialog (back). The device setting is applied and appears in the **Devices** overview, which you close with **Close**.

**NOTE**

The slot now shows **ATR833 on BLE port: SD-ATR833**. As long as the radio is not connected, **No data** is shown below it; after a successful connection the display changes to **Connected**. If necessary, trigger the connection via **Reconnect**.

Port	
Headset	Bluetooth
Speaker	Bluetooth
4C:83:99:A9:47:FB	BLE sensor
<b>SD-ATR833</b>	<b>BLE port</b>
F1:B9:19:E2:9A:62	BLE sensor
5D:AB:17:33:4D:82	BLE sensor

Select      Cancel

Devices
A: Built-in GPS & sensors Connected
<b>B: ATR833 on BLE port: SD-ATR833</b> Connected
C: Disabled Disabled
D: Disabled Disabled

Close      Edit      Reconnect

Schematic representation of the XCSoar interface (Android), not an original screenshot: port selection (left), **Devices** overview with connected adapter (right).

### 3.3 Sending a frequency to the radio

- On the map, tap an airfield or waypoint that has a radio frequency stored. The list **Map elements at this location** opens.
- Select the desired entry and tap **Details**.

- ③ Use the arrows ◀ ▶ at the bottom to go to the page with **Set Active Frequency** and **Set Standby Frequency** and tap the desired option.

**NOTE**

**Set Active Frequency** transmits the frequency to the radio's active frequency, **Set Standby Frequency** to the standby frequency.

### Map elements at this location

NORDHEIM (EDXN)  
843 ft · 122.305 MHz

**WESTAU (EDXW)**  
1502 ft · 119.625 MHz

SUEDFELD (EDXS)  
1188 ft · 118.075 MHz

OSTBERG (EDXO)  
2014 ft · 120.350 MHz

Details   Goto   Close

### Waypoint: WESTAU

Pan to Waypoint

→ **Set Active Frequency**

→ **Set Standby Frequency**

Edit

◀   ▶   Close

*Schematic representation of the XCSoar interface (Android), not an original screenshot: **Map elements** with airfield frequency (left), **waypoint menu** with **Set Active/Standby Frequency** (right).*

## 4 Contact

For problems, questions, suggestions, or positive feedback, please contact:

### LayCom Vision GmbH – SD-Link

Michael Hoffmann

Chausseestr. 46  
D-15518 Rauen, Germany

E-Mail [info@sdlink.de](mailto:info@sdlink.de)

Phone [+49 3361 710253](tel:+493361710253)

Web [www.sdlink.de](http://www.sdlink.de)



## Dimensions

