

f.u.n.k.e ATR833 – angled Adapter BLE Bluetooth

XCSoar (Android) EXPERIMENTAL

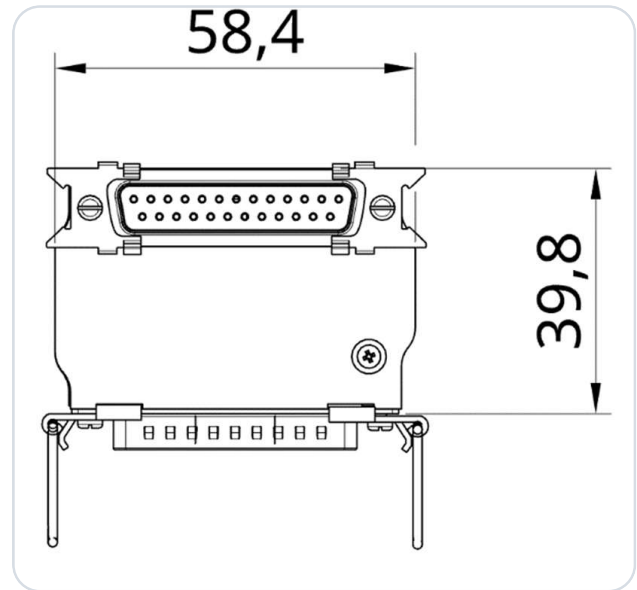

Angled version of the Bluetooth Low Energy adapter (BLE) for a f.u.n.k.e ATR833 VHF transceiver (aviation radio), for installations with limited space behind the radio, compatible with ATR833, ATR833S, ATR833A, ATR833-II, ATR833A-II.

The adapter was developed as an interface between an ATR833 and the navigation software SkyDemon (SD). It implements the data transfer between the navigation software (SD) and the radio hardware (BLE ↔ RS-232). The adapter simply plugs between the existing wiring and the radio and holds to the housing thanks to the Molex Spring Lock system.

No additional power supply is necessary. The adapter can be operated with 12 V and 24 V aircraft voltage. An internal mini-fuse (125 mA) is integrated in the housing. The power supply is protected against reverse polarity and short circuits.

No further electrical or mechanical work necessary!

IMPORTANT

This is a prototype for experimental use only!

1 Radio Configuration

IMPORTANT

Supported are ATR833-S, ATR833-A and ATR833-II-OLED from software SW 5.8. Older versions (≤ 5.7) are not compatible. First supported serial number: 40131610 (2010). Tip: the last two digits of the serial number = year of production.

No further configuration is required on the radio.

2 Connector Pin Assignment

This is an excerpt from the f.u.n.k.e installation manual:

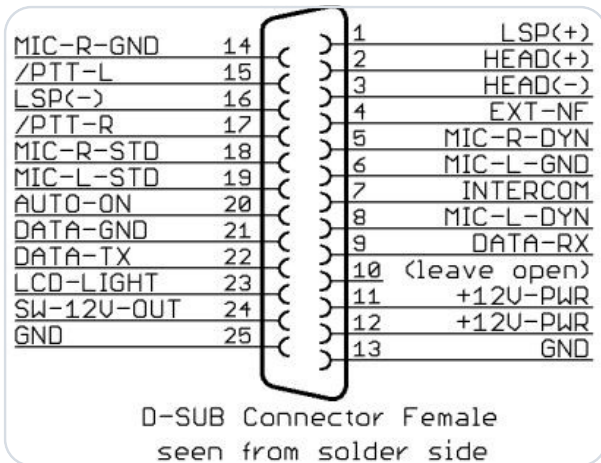

Figure 1 · Old version (ATR833)

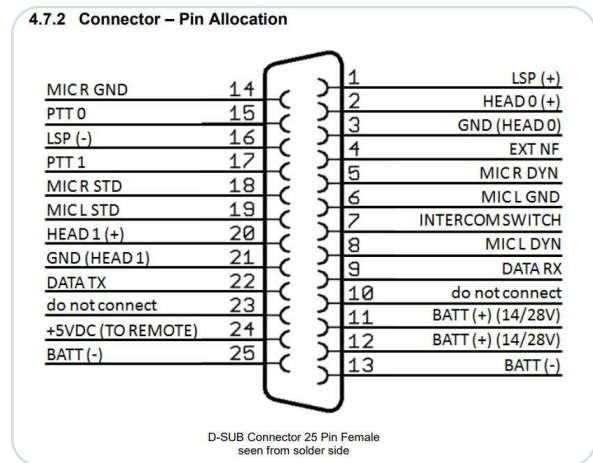

Figure 2 · New version (ATR833-II)

D-SUB 25-Pin · Pin Allocation in Detail

D-SUB 25-pin female connector, solder side. Complete allocation according to the f.u.n.k.e manual.

PIN	NAME	FUNCTION
1	LSP (+)	Output external Loudspeaker Positive
2	HEAD-0 (+)	Output Headset-Speaker Positive
3	GND (HEAD-0)	Output Headset-Speaker Negative
4	EXT-NF	Input external Audio-Signal
5	MIC R DYN	Input Microphone Right Dynamic
6	MIC L GND	Input Microphone Left Ground
7	INTERCOM SWITCH	Intercom Activation Switch (connect to ground for Intercom activation)
8	MIC L DYN	Input Microphone Left Dynamic
9	DATA-RX	RS232 Receive (for Remote Control)
10	do not connect	Pin 10 is used by adapters for device identification
11	+14 / +28V-PWR	Input Power Supply +12V
12	+14 / +28V-PWR	Input Power Supply +12V
13	BATT (-)	Ground Side of Power Supply
14	MIC R GND	Input Microphone Right Ground
15	PTT-0	Push-to-Talk 0 (connect to ground for transmitting)
16	LSP (-)	Output external Loudspeaker Negative (Not identical to ground!)
17	PTT-1	Push-to-Talk 1 (connect to ground for transmitting)
18	MIC R STD	Input Microphone Right (Headset 1)
19	MIC L STD	Input Microphone Left (Headset 0)
20	HEAD 1 (+)	Output 1 Headset-Speaker Positive
21	GND (HEAD 1)	Output 1 Headset-Speaker Negative
22	DATA-TX	RS232 TX (for Remote Control)
23	N/A	do not connect
24	+5VDC OUT	5VDC Power Supply for Remote Control
25	BATT (-)	Ground Side of Power Supply

Source: f.u.n.k.e manual.

3 Product Variants

The orientation of the connector varies depending on the radio model. Therefore, pay attention to the direction in which the adapter should be angled. For this reason, we offer the product variants **LEFT** and **RIGHT**.

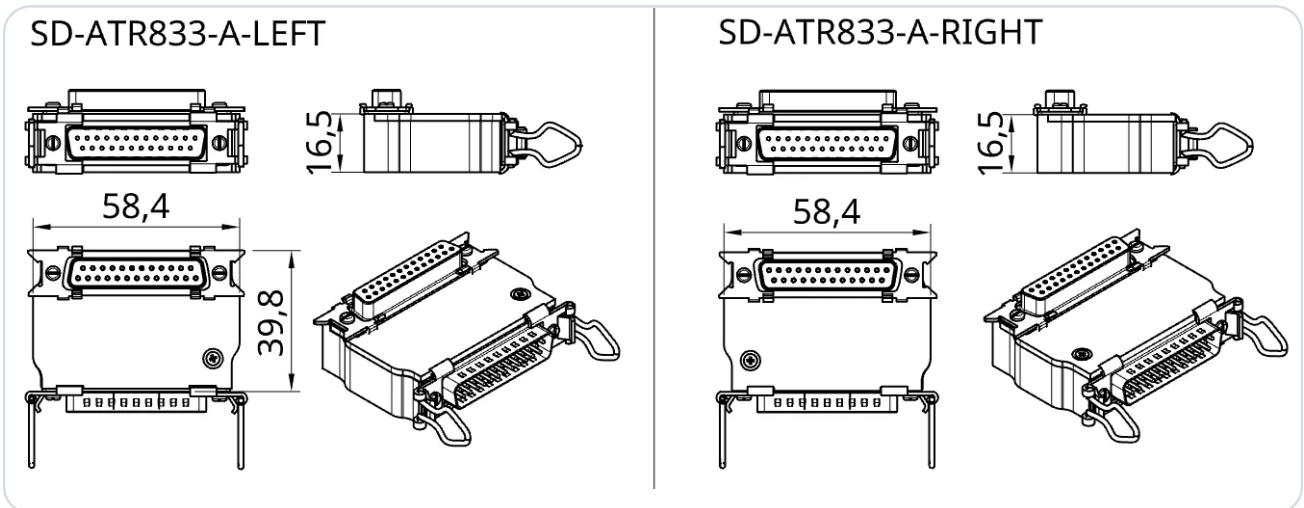

Here is an overview table for orientation:

RADIO	DESIRED ORIENTATION	REQUIRED ADAPTER
ATR833-II-LCD/OLED	Points downward	SD-ATR833-A-LEFT
ATR833-II-LCD/OLED	Points upward	Mounting blocked – antenna socket
ATR833A	Points downward	SD-ATR833-A-RIGHT
ATR833A	Points upward	SD-ATR833-A-LEFT
ATR833A-II-LCD/OLED	Points downward	SD-ATR833-A-RIGHT
ATR833A-II-LCD/OLED	Points upward	SD-ATR833-A-LEFT
ATR833S	Points downward	SD-ATR833-A-LEFT
ATR833S	Points upward	Mounting blocked – antenna socket

NOTE

If you are unsure which adapter you need, please send us a picture of the back of your radio or provide the model number at info@sdlink.de.

4 Configuration in XCSoar

IMPORTANT

Do not pair the SD-Link in the Bluetooth settings

The SD-Link adapter is a Bluetooth Low Energy (BLE) device. BLE devices are not paired via the Bluetooth settings of your tablet or phone like regular Bluetooth devices such as headsets or speakers.

Therefore, please do not open the Bluetooth settings of iOS, Android or Windows to search for or pair the SD-Link there.

The connection to the SD-Link is set up exclusively within the navigation app itself, e.g. in SkyDemon, Sky-Map, VFRnav, EasyVFR or another supported app. Pairing at operating-system level is not required and can even prevent the connection.

Regular Bluetooth devices such as headsets, intercoms or speakers can still be used in parallel. They are paired via the operating system as usual. The SD-Link, however, is addressed directly by the navigation app.

If the SD-Link has already been paired in the Bluetooth settings: Please remove the SD-Link completely from the Bluetooth device list of your tablet or phone. Do not pair it again via the operating system afterwards; instead, set it up again exclusively within the navigation app.

REMEMBER

**Do not pair the SD-Link in the operating system.
Always set up the SD-Link directly in the navigation app.**

IMPORTANT

XCSoar: experimental and Android only

This guide describes the tested setup with XCSoar on **Android** (tested from XCSoar 7.42 onwards). XCSoar support is experimental and depends on the XCSoar version, the Android device and the radio driver.

On **iOS**, up to and including version 7.44, XCSoar offers – according to our testing – no BLE port for external devices; only internal sensors and TCP/UDP are available as port types, so the SD-ATR833-A cannot be used directly on iOS. For iOS, please use one of the other supported apps (e.g. SkyDemon).

4.1 Requirements

- Onboard power on, radio switched on.
- Switch on Bluetooth on your Android device.
- Start XCSoar.

NOTE

No pairing is required. The SD-ATR833-A is a BLE device and is selected exclusively within XCSoar – not in the Bluetooth settings of Android (see the note above).

4.2 Adding the device in XCSoar

- ① Double-tap the map view to open the menu and select **Config** → **Devices**.
- ② Choose a free slot (e.g. **B**) and tap **Edit**.

- Open **Port**, select the entry **SD-ATR833** with the type **BLE port** and confirm with **Select**.

IMPORTANT NOTICE

Make sure to pick the type **BLE port**. Entries with a bare MAC address or the type **BLE sensor** are not correct; classic **Bluetooth** devices (e.g. headsets) are not correct either. No pairing is required.

- As **Driver**, select the radio type **ATR833**.
- Leave the edit dialog (back). The device setting is applied and appears in the **Devices** overview, which you close with **Close**.

NOTE

The slot now shows **ATR833 on BLE port: SD-ATR833**. As long as the radio is not connected, **No data** is shown below it; after a successful connection the display changes to **Connected**. If necessary, trigger the connection via **Reconnect**.

Port	
Headset	Bluetooth
Speaker	Bluetooth
4C:83:99:A9:47:FB	BLE sensor
SD-ATR833	BLE port
F1:B9:19:E2:9A:62	BLE sensor
5D:AB:17:33:4D:82	BLE sensor

Select Cancel

Devices
A: Built-in GPS & sensors Connected
B: ATR833 on BLE port: SD-ATR833 Connected
C: Disabled Disabled
D: Disabled Disabled

Close Edit Reconnect

Schematic representation of the XCSoar interface (Android), not an original screenshot: *port selection (left), Devices overview with connected adapter (right).*

4.3 Sending a frequency to the radio

- On the map, tap an airfield or waypoint that has a radio frequency stored. The list **Map elements at this location** opens.
- Select the desired entry and tap **Details**.

- ③ Use the arrows ◀ ▶ at the bottom to go to the page with **Set Active Frequency** and **Set Standby Frequency** and tap the desired option.

NOTE

Set Active Frequency transmits the frequency to the radio's active frequency, **Set Standby Frequency** to the standby frequency.

Map elements at this location

NORDHEIM (EDXN)
843 ft · 122.305 MHz

WESTAU (EDXW)
1502 ft · 119.625 MHz

SUEDFELD (EDXS)
1188 ft · 118.075 MHz

OSTBERG (EDXO)
2014 ft · 120.350 MHz

Details Goto Close

Waypoint: WESTAU

Pan to Waypoint

→ **Set Active Frequency**

→ **Set Standby Frequency**

Edit

◀ ▶ Close

*Schematic representation of the XCSoar interface (Android), not an original screenshot: **Map elements** with airfield frequency (left), **waypoint menu** with **Set Active/Standby Frequency** (right).*

5 Contact

For problems, questions, suggestions or positive feedback, please contact:

LayCom Vision GmbH – SD-Link

Michael Hoffmann

Chausseestr. 46
D-15518 Rauen, Germany

E-Mail info@sdlink.de

Phone **+49 3361 710253**

Web www.sdlink.de

