

f.u.n.k.e ATR833 – angled Adapter BLE Bluetooth

vfrNav EXPERIMENTAL

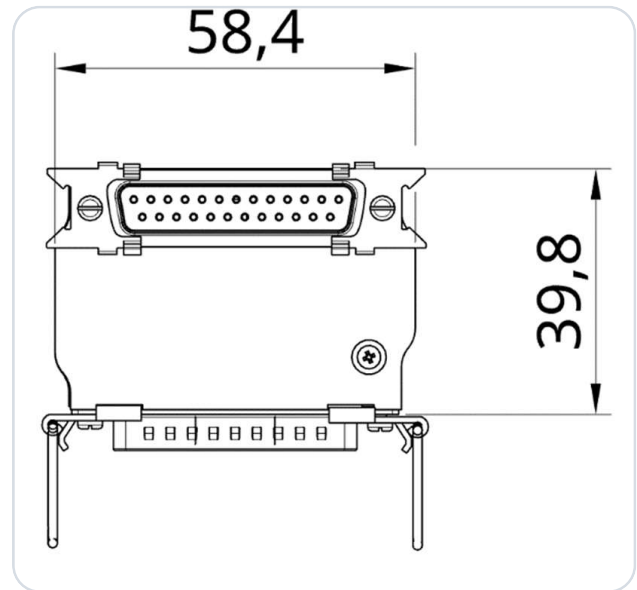

Angled version of the Bluetooth Low Energy adapter (BLE) for a f.u.n.k.e ATR833 VHF transceiver (aviation radio), for installations with limited space behind the radio, compatible with ATR833, ATR833S, ATR833A, ATR833-II, ATR833A-II.

The adapter was developed as an interface between an ATR833 and the navigation software vfrNav. It implements the data transfer between the navigation software (vfrNav) and the radio hardware (BLE ↔ RS-232). The adapter simply plugs between the existing wiring and the radio and holds to the housing thanks to the Molex Spring Lock system.

No additional power supply is necessary. The adapter can be operated with 12 V and 24 V aircraft voltage. An internal mini-fuse (125 mA) is integrated in the housing. The power supply is protected against reverse polarity and short circuits.

No further electrical or mechanical work necessary!

IMPORTANT

This is a prototype for experimental use only!

1 Radio Configuration

IMPORTANT

Supported are ATR833-S, ATR833-A and ATR833-II-OLED from software SW 5.8. Older versions (≤ 5.7) are not compatible. First supported serial number: 40131610 (2010). Tip: the last two digits of the serial number = year of production.

No further configuration is required on the radio.

2 Connector Pin Assignment

This is an excerpt from the f.u.n.k.e installation manual:

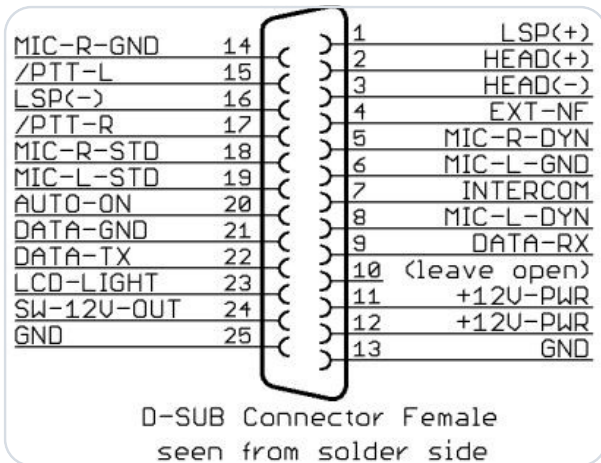

Figure 1 · Old version (ATR833)

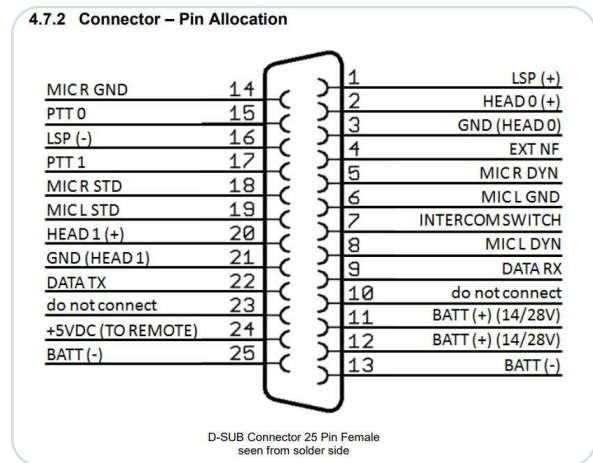

Figure 2 · New version (ATR833-II)

D-SUB 25-Pin · Pin Allocation in Detail

D-SUB 25-pin female connector, solder side. Complete allocation according to the f.u.n.k.e manual.

PIN	NAME	FUNCTION
1	LSP (+)	Output external Loudspeaker Positive
2	HEAD-0 (+)	Output Headset-Speaker Positive
3	GND (HEAD-0)	Output Headset-Speaker Negative
4	EXT-NF	Input external Audio-Signal
5	MIC R DYN	Input Microphone Right Dynamic
6	MIC L GND	Input Microphone Left Ground
7	INTERCOM SWITCH	Intercom Activation Switch (connect to ground for Intercom activation)
8	MIC L DYN	Input Microphone Left Dynamic
9	DATA-RX	RS232 Receive (for Remote Control)
10	do not connect	Pin 10 is used by adapters for device identification
11	+14 / +28V-PWR	Input Power Supply +12V
12	+14 / +28V-PWR	Input Power Supply +12V
13	BATT (-)	Ground Side of Power Supply
14	MIC R GND	Input Microphone Right Ground
15	PTT-0	Push-to-Talk 0 (connect to ground for transmitting)
16	LSP (-)	Output external Loudspeaker Negative (Not identical to ground!)
17	PTT-1	Push-to-Talk 1 (connect to ground for transmitting)
18	MIC R STD	Input Microphone Right (Headset 1)
19	MIC L STD	Input Microphone Left (Headset 0)
20	HEAD 1 (+)	Output 1 Headset-Speaker Positive
21	GND (HEAD 1)	Output 1 Headset-Speaker Negative
22	DATA-TX	RS232 TX (for Remote Control)
23	N/A	do not connect
24	+5VDC OUT	5VDC Power Supply for Remote Control
25	BATT (-)	Ground Side of Power Supply

Source: f.u.n.k.e manual.

3 Product Variants

The orientation of the connector varies depending on the radio model. Therefore, pay attention to the direction in which the adapter should be angled. For this reason, we offer the product variants **LEFT** and **RIGHT**.

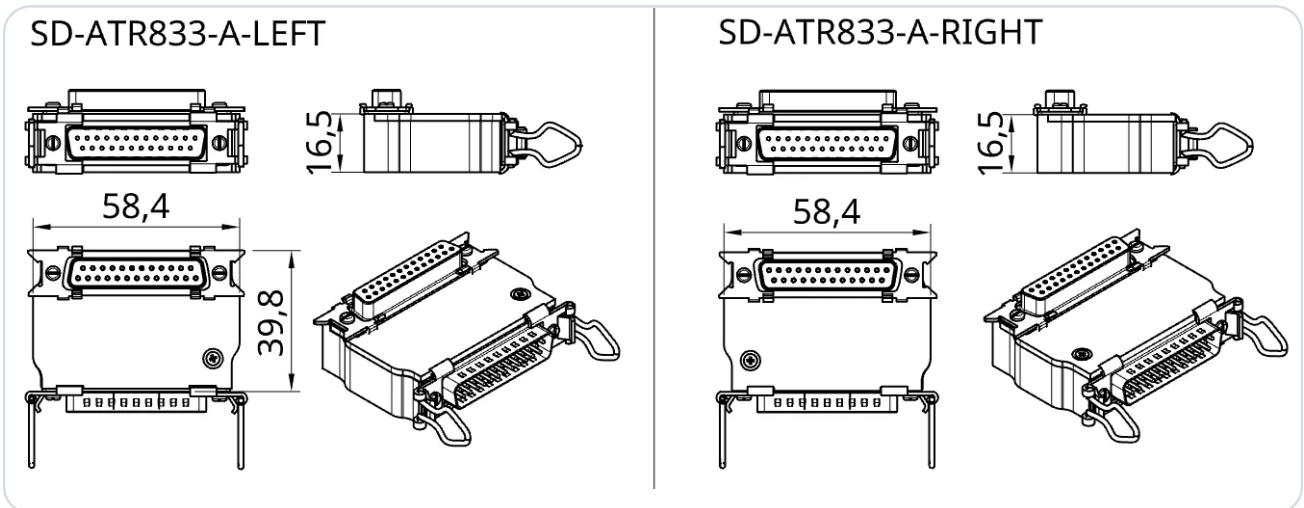

Here is an overview table for orientation:

RADIO	DESIRED ORIENTATION	REQUIRED ADAPTER
ATR833-II-LCD/OLED	Points downward	SD-ATR833-A-LEFT
ATR833-II-LCD/OLED	Points upward	Mounting blocked – antenna socket
ATR833A	Points downward	SD-ATR833-A-RIGHT
ATR833A	Points upward	SD-ATR833-A-LEFT
ATR833A-II-LCD/OLED	Points downward	SD-ATR833-A-RIGHT
ATR833A-II-LCD/OLED	Points upward	SD-ATR833-A-LEFT
ATR833S	Points downward	SD-ATR833-A-LEFT
ATR833S	Points upward	Mounting blocked – antenna socket

NOTE

If you are unsure which adapter you need, please send us a picture of the back of your radio or provide the model number at info@sdlink.de.

4 Configuration in vfrNav

IMPORTANT

Do not pair the SD-Link in the Bluetooth settings

The SD-Link adapter is a Bluetooth Low Energy (BLE) device. BLE devices are not paired via the Bluetooth settings of your tablet or phone like regular Bluetooth devices such as headsets or speakers.

Therefore, please do not open the Bluetooth settings of iOS, Android or Windows to search for or pair the SD-Link there.

The connection to the SD-Link is set up exclusively within the navigation app itself, e.g. in SkyDemon, Sky-Map, VFRnav, EasyVFR or another supported app. Pairing at operating-system level is not required and can even prevent the connection.

Regular Bluetooth devices such as headsets, intercoms or speakers can still be used in parallel. They are paired via the operating system as usual. The SD-Link, however, is addressed directly by the navigation app.

If the SD-Link has already been paired in the Bluetooth settings: Please remove the SD-Link completely from the Bluetooth device list of your tablet or phone. Do not pair it again via the operating system afterwards; instead, set it up again exclusively within the navigation app.

REMEMBER

Do not pair the SD-Link in the operating system.

Always set up the SD-Link directly in the navigation app.



- Switch on aircraft power, turn on the radio.
- Enable Bluetooth on your phone/tablet.
- Start vfrNav.
 - ① Open menu
 - ② Open settings menu
 - ③ Under Device connections → Radio
 - ④ Select interface

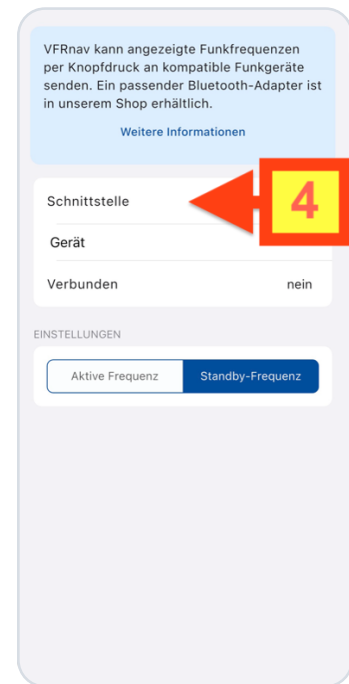
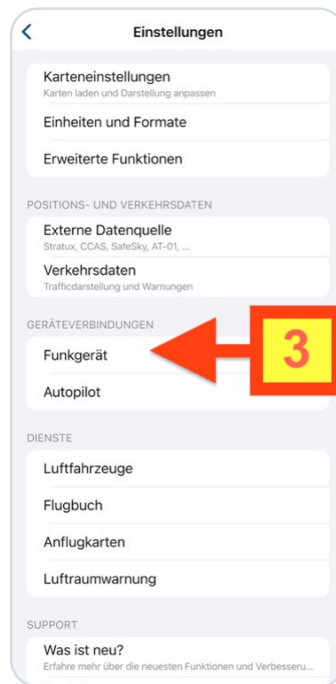
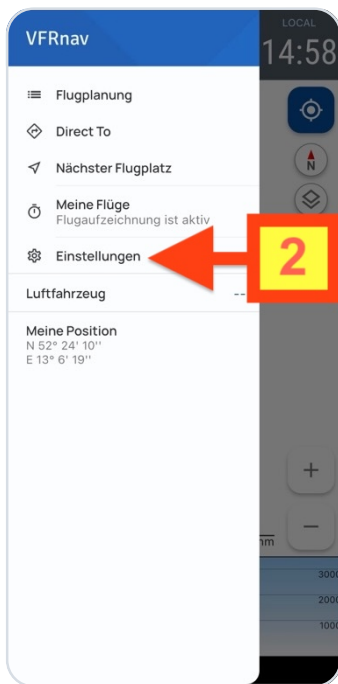

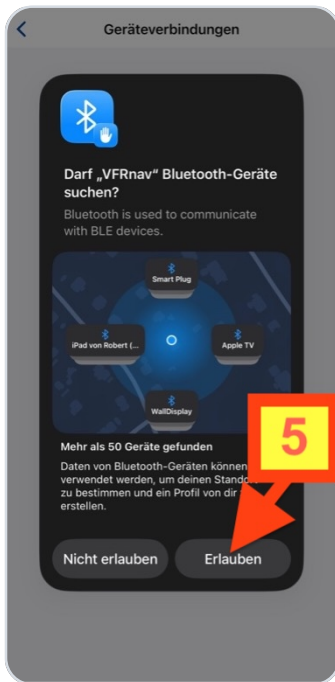

- ⑤ Enable Bluetooth if necessary
- ⑥ Select the name of the found adapter: **SD-ATR833**
- ⑦ If the protocol was not automatically detected, please adjust it under "Device".
- ⑧ In the connection settings, specify whether the frequency should be transmitted to the radio immediately as active or as standby.

IMPORTANT NOTICE

Check under "Connected": It should say "yes".

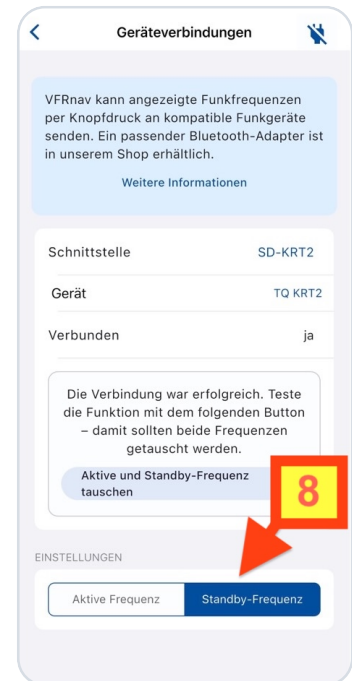
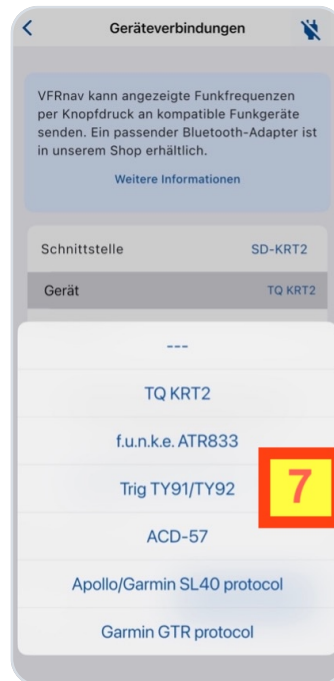
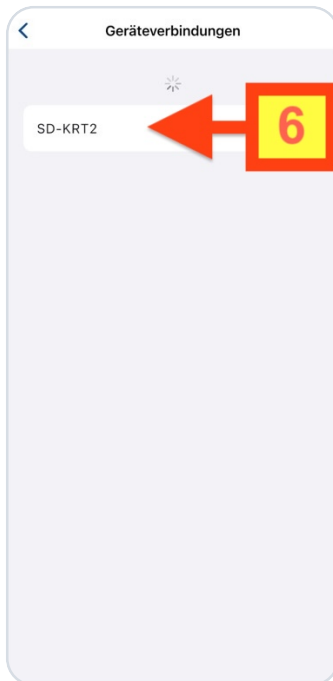

5 Contact

For problems, questions, suggestions or positive feedback, please contact:

LayCom Vision GmbH – SD-Link

Michael Hoffmann

Chausseestr. 46
D-15518 Rauen, Germany

E-Mail info@sdlink.de

Phone **+49 3361 710253**

Web www.sdlink.de

